

**D-31 Series, Rated up to 100 Amps, 115/200 VAC, 400 Hz**

**Product Facts**

- 3PDT, Center off
- Hermetically sealed
- Auxiliary contacts available
- Meets many requirements of MIL-PRF-6106



**Performance Data**

**Electrical Characteristics**

**Contact Arrangement** — 3PDT, Center Off

**Rated Operating Voltage** — 115/200 VAC, 400 Hz, 3 phase

**Resistive Rating** — 100 Amps

**General Characteristics**

**Temperature Range** — -55°C to +71°C

**Operating Cycles (Life) at Rated Resistive Load, Min.** — 50,000 cycles

**Operating Cycles (Life) Mechanical, Min.** — 100,000 cycles

**Dielectric Strength** — All Circuits to Ground — 1,500 Vrms  
Circuit to Circuit — 1,500 Vrms  
Coil to Ground and Aux. Contacts — 1,000 Vrms

**Altitude** — 50,000 ft  
**Weight, Max.** — 2.31 lbs

**Coil Characteristics**

**Duty Cycle** — Continuous  
**Operating Voltage, Nom.** — 28 Vdc  
**Pickup Voltage @ 71°C, Max.** — 18 Vdc

**Dropout Voltage, Max.** — 1.5 to 7 Vdc

**Coil Resistance ±20% @ 25°C** — 160 Ohms

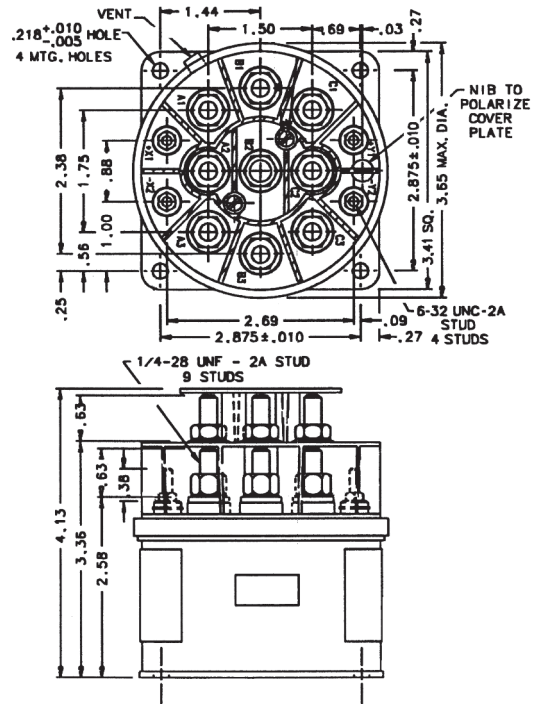

Mounting Style A

**Circuit Configurations** (Consult factory for other available circuit configurations)

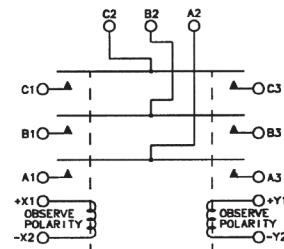

Circuit Configuration 1

For factory-direct application assistance, phone 419-521-9500 or fax 419-526-2749.

HARTMAN Part Number	Construction Type	Mounting Style	Coil Type	Circuit Config.	TE Part Number
D-31C	Gasket/Vented	A	Continuous	1	1616049-1